

QPF-500 HYBRID DOCK

ALUMINUM DOCK FRAME ASSEMBLY INSTRUCTION

1- PLACE THE 2 SIDE EXTRUSIONS (A) ON A FLAT SURFACE, WITH THE DECKING LIP SUPPORT ON TOP, THE CENTRAL TUBE (B) AND THE TWO END PIECES (C) WITH THE DECKING LIP SUPPORT ON THE BOTTOM.

2- INSERT THE CENTRAL TUBE (B) IN THE ATTACHMENT BRACKET (D) OF ONE OF THE SIDE EXTRUSIONS (A) AND BOLT ON WITH ONE OF THE FOUR 2-1/2" LONG BOLT, THEN SLIDE THE 2 END PIECES (C) IN THE SAME SIDE EXTRUSION, DECKING LIP ON THE BOTTOM.

3- INSERT THE SECOND SIDE EXTRUSION (A) IN THE TWO END PIECES (C) AND SLIDE IN SLOWLY, GOING TO ONE SIDE THEN THE OTHER (be careful to insert the central tube (B) in its attachment bracket (D) before it's all in), HITTING WITH A PLASTIC HAMMER IF NECESSARY (protect with a piece of wood prior to hit with the hammer!) TO MAKE SURE THAT PENETRATION WILL BE TO THE BOTTOM, AND BOLT THE CENTRAL TUBE (B) IN ITS ATTACHMENT BRACKET OF THE OTHER SIDE EXTRUSION (D).

4- CUT OUT THE PAPER TEMPLATE AT THE BOTTOM OF THIS PLAN, PERFORATE IT AND USE IT TO MARK WITH A MARKER THE END PIECES (C) AT THEIR ENDS (picture no.1). PUT THE TEMPLATE IN THE LITTLE LIP AND AGAINST THE CORNER LEG HOLDER.

5- DRILLING ALUMINUM IS AS EASY AS DRILLING INTO HARD WOOD. DRILL THE HOLES YOU JUST MARKED WITH A DRILL BIT SIZE 13/64" AND SCREW IN WITH A RATCHET AND A 3/8" SOCKET. DO NOT TIGHT MORE THAN 22 POUNDS OF PRESSURE (or around 1/6 of a turn or 66 degrees once the head of the bolt has sit on the surface). IF EVER YOU STRIP A SCREW, DON'T WORRY! JUST DRILL ANOTHER HOLE BESIDE IT (in the interior side of the 4 screws) AND SCREW AGAIN (the strength of the dock will be exactly the same).

6- MARK THE END PIECES (C) AT 18 1/2" FROM EACH SIDES (drawing #6) AND INSERT THE DECKING SUPPORTS (F) CENTER TO THOSE MARKS (the hole of these decking supports (F) has to align with the hole of the centre tube (B)) IF THE SUPPORT SEEMS A LITTLE TOO LONG, YOU CAN PUSH WITH YOUR FOOT AND PULL AS ON PICTURE NO.2 OR YOU MAY AJUST THE ENDS BY HITTING THEM LIGHTLY WITH A PLASTIC HAMMER (picture no.3). THEN BOLT TO CENTRE TUBE WITH THE 2-1/2" BOLTS. THEN CONFIRM THE ALIGNMENT (parallelism) OF THE SUPPORTS (F) WITH THE SIDE EXTRUSION (A). READJUST AT THE ENDS IF NECESSARY, THEN DRILL AND SCREW WITH 2 SCREWS AT EACH ENDS, THE PLATE OF THOSE SUPPORTS IN THE END PIECES THE SAME WAY YOU DID AT STEP NO.5 (make sure that the end plates of the supports (F) are well inserted deeply to the bottom of the little supporting lip) (picture no.4).

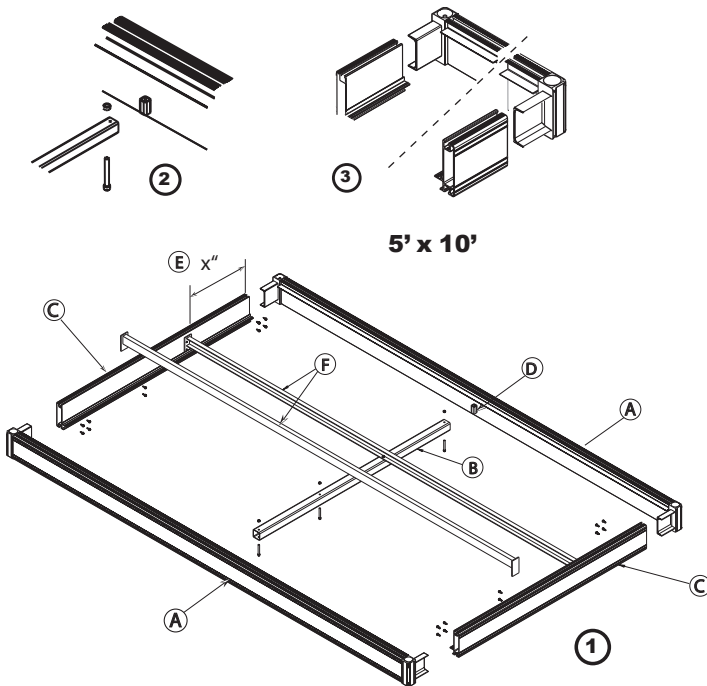

 **multinautic.com**
1-800-585-1237

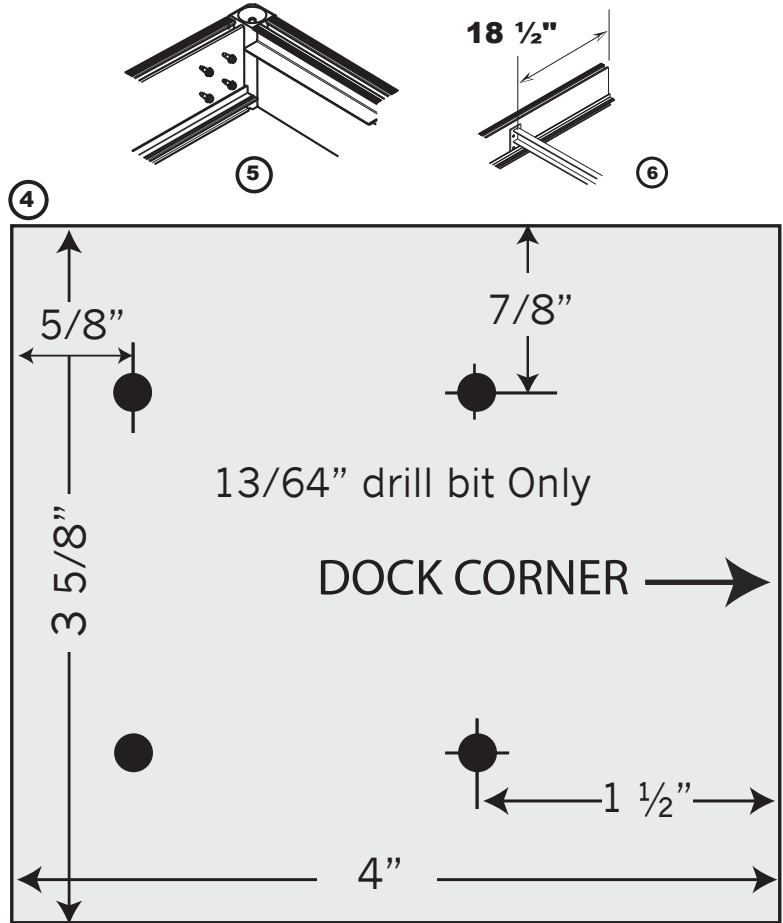

REQUIRED TOOLS

- 1/4" Allen Key
- 3/8" Ratchet & Socket (to assemble the structure)
- Cordless drill with 13/64" drill bit (to assemble frame) & 11/64" drill bit (to assemble decking)
- Small plastic sledgehammer
- Square bit #2

FRAME PARTS INCLUDED

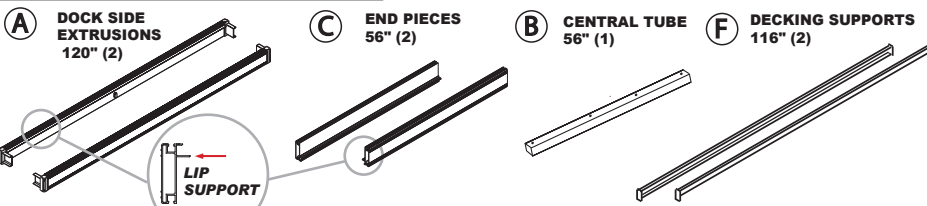

- | | | |
|---|---------------------------------|--|
| HEXAGONAL BOLTS & LOCK NUTS
2 1/2" x 1/4" (4) | ALLEN SCREWS
1/2" (8) | HEX. FLAT METAL SCREWS
#14 x 3/4" (26)
(2 extras) |
|---|---------------------------------|--|

